

GPS Ready

This application diagram depicts a flight deck GPS status annunciator that has built-in voltage sense circuitry which is used to monitor a status input signal. Depending on the voltage level of the status input, the annunciator will indicate the active state of the GPS system and equipment.

The design uses a single annunciator that has a VIVISUN Compact Body which houses two NEXSYS Voltage Sensor (VSD1) components. The upper VSD1 is configured to output a low (ground) when the sensed input signal is below 1.0 VDC. The lower VSD1 is configured to output a low (ground) when the sensed input signal is above 2.5 VDC. The outputs of both VSD1 are high-z (open) when inactive.

The GPS status signal is +3.3 VDC when the system is ready and functioning properly and 0 VDC (ground) when there is a fault in the system. If the upper VSD1 senses 0 VDC (ground) on input SEN (A3), output Z (A1) will become low (ground) which causes the GPS FAULT (A) indicator to illuminate. This state is held so long as the status signal voltage level is 0 VDC. If the lower VSD1 senses +3.3 VDC on input SEN (B3), output Z (B1) will become low (ground) which causes the GPS READY (B) indicator to illuminate. This state is held so long as the signal voltage level is 3.3 VDC.

To speak with our Technical Support team on how NEXSYS Component Technology can be used to add avionics system capabilities or solve your system integration challenges call us at 1-888-848-4786.

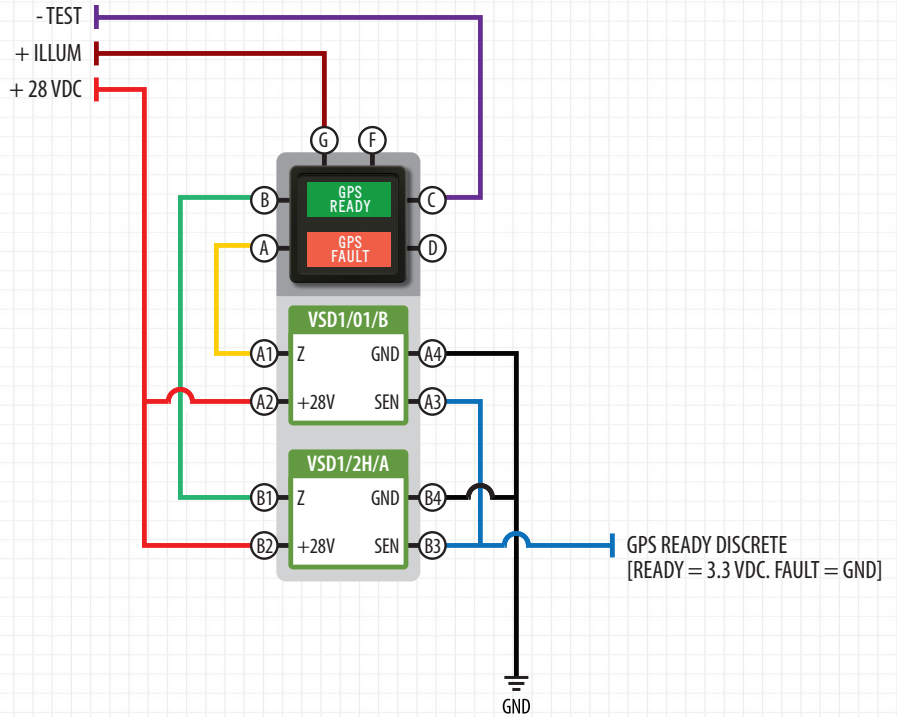

To view online, visit www.appliedavionics.com/apx/apx-053.html

